

SB-1 / SB-2 series manual



KEETON
INDUSTRIES

OTHER PONDS AND LAKES ARE GREEN WITH ENVY™
1520 Aquatic Drive, Wellington CO 80549 • KeetonAquatics.com • toll-free: 800.493.4831 • fax: 970.568.7795

congratulations!

Dear Valued Customer,

Congratulations on your purchase of a Keeton Industries Solaer™ Lake Bed Aeration System™! In the following pages you will find detailed information about the system you have purchased. These include a system checklist, installation instructions, required maintenance, warranty information and much more.

Please read through this content and familiarize yourself with your new system and how it works.

All our best,
Keeton Industries

IMPORTANT

This equipment was thoroughly inspected and carefully packaged in our facility. Upon acceptance by the carrier (UPS, USPS, Motor Freight or Other) they assume responsibility for the goods in transit and their ultimate safe arrival. Should you receive your shipment in a damaged condition, either apparent or concealed; a damage claim must be made by you, the customer, directly with the shipping carrier. Keeton Industries cannot make this claim for you.

APPARENT LOSS or damage

Should visual inspection upon receipt of goods show loss or damage, it must be noted on the freight bill, express receipt, or UPS driver's record and signed by the driver or agent. Failure to do so will result in the carrier refusing to honor your damage claim. The carrier will furnish you the necessary form(s) for filing a claim should they be needed.

CONCEALED damage

When damage is not apparent until the equipment is unpackaged, a claim for concealed damage is to be made to the carrier. When damage is discovered, make a written or phone request to the carrier for inspection. You must make this request for inspection **within forty-eight (48) hours** of delivery. Immediately inspect all packages for exterior and interior damage or loss upon receipt and make any claims as soon as possible. Keep all cartons and packaging material to show the inspector. The carrier will furnish you with an inspection report and necessary forms for filling a concealed damage claim, since such damage is the carrier's responsibility.

RETURNS

If you are unhappy with your order for any reason, Keeton Industries will gladly exchange items; issue credit or refund the purchase price to you (less restocking charges) within 7 days of receiving the product. In all cases, return freight costs are the responsibility of the customer.

Please call or write for Return Authorization Number so that we may handle your return as quickly and efficiently as possible. We will not accept any returned merchandise without a Return Authorization Number being displayed on the package.

NOTICE

There are no returns on Custom Designed equipment or Manufactured equipment for specific applications.

SYSTEM checklist

INSIDE THE 100% RECYCLED PLASTIC CABINET:

- PROGRAMMABLE DIGITAL TIMER :** Controls on/off function. (See page 5)
- ADJUSTABLE MANIFOLD :** Allows airflow to be adjusted to the diffusers.
- COMPRESSOR :** 24V EcoFlow compressor generates compressed air.
- AIR INTAKE FILTER :** Prevents dust & dirt from damaging the compressor.
- ACOUSTICAL SOUND PROOF FOAM :** Keeps system "quiet".

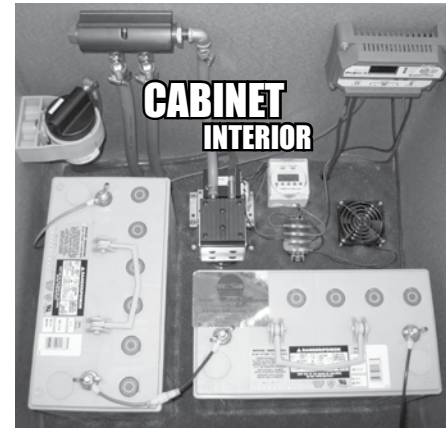

THE SOLAR PANEL

The Solar Panel furnished with this system is a result of rigorous quality control applied throughout the production process from cells to modules. The modules are made with silicon refined in the U.S. using renewable energy and are square multicrystalline solar cells laminated behind high-transparency glass with an anti-reflective surface treatment.

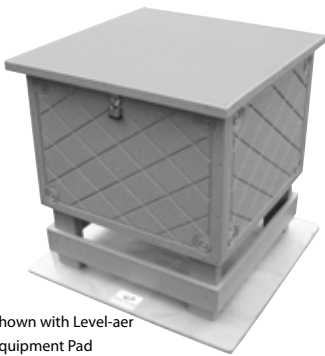

Shown with Level-aer
Equipment Pad
– additional upgrade.

THE CABINET

Our 100% recycled plastic cabinets, acoustical foam and sound dampening isolators work to eliminate escaping sound. The high capacity cooling blower works to maintain proper temperatures for optimum performance even in the most inhospitable locations. A digital timer offers flexibility and allows the system to run during certain times, such as at night only. The systems also include a fully adjustable aluminum distribution manifold.

THE DIFFUSERS

Our aeration systems use Duraplate™ self-cleaning, non-clogging membrane diffusers. The Duraplate diffuser is designed to create a large amount of laminar circulation to eliminate stratification. The Duraplate diffusers also offer a very high oxygen transfer rate to increase dissolved oxygen levels at all levels in the pond from the surface to the bottom. Due to their design, the Duraplate diffusers will not need to be removed for cleaning and are backed by a lifetime warranty. The rotationally molded Duraplate diffuser shell is also fishhook resistant, making them an ideal choice for fishing ponds and lakes.



THE TUBING (optional)

Keeton Industries Alpine™ self-weighted feeder tubing offers the perfect balance of flexibility and weight. Alpine tubing sinks directly to the bottom and will not kink or break. Alpine tubing is a high density, flexible tubing that features a thick, ¼" sidewall. Available in 100' rolls and 500' reels.

INSTALLATION procedure

PLEASE READ ALL INSTRUCTIONS CAREFULLY PRIOR TO INSTALLING YOUR LAKE BED AERATION SYSTEM.

equipment



SCREW DRIVER



TUBING CUTTER



WRENCH



A BOAT WITH MOTOR OR OARS



SHOVEL



OPEN END WRENCHES -
7/16" AND 1/2"



SOCKET SET



HAMMER

SOLAR PANEL

1 Determine the installation location, which must have unobstructed views of solar south and out of the shadow path of any nearby structures or vegetation.

2 Inspect top pole mount to determine the outside diameter size of schedule 40 steel pole to be purchased locally. Mount this pole into the ground; please see top pole mount instructions to determine the total pole length and the amount to be buried in the ground. It is very common to have as much as 6' of pole above ground. In areas with very heavy snow fall, a longer pole may be required. It is recommended to secure the solar panel mounting pole by filling the hole with concrete. Allow enough time for the concrete to cure before proceeding with the solar panel mounting instructions.

3 Place the compressor housing (cabinet) next to the mounting pole. The cabinet comes with four legs and is a free standing unit. You can pour a concrete pad to set the cabinet on if desired. Otherwise, the cabinet can be placed directly on level ground or on concrete pavers. In some situations (36"L by 36"W, large cabinets), it may be necessary to support the bottom of the cabinet with concrete blocks due to the weight of the batteries in the cabinet.

4 Mount Panel to top pole mount. Please refer to panel mounting instructions included in top pole mount box. All hardware has been included with panel mount. Solar panel will be prewired and ready for electrical hookup.

5 Set solar module tilt angle. Solar panel produce the most power when they are pointed directly at the sun. The module tilt angle is measured between the solar modules and the ground. Panel angle will need to be determined using the chart below:

Recommended Tilt Angles for a Fixed System

SITE LATITUDE IN DEGREES	FIXED TILT ANGLE IN DEGREES
0° to 15°	15°
15° to 25°	Same as Latitude
25° to 30°	Latitude + 5°
30° to 35°	Latitude - 10°
35° to 40°	Latitude - 15°
40°+	Latitude - 20°

6 Solar Panel Connection: Interlocking cables are provided with the system. Male and female connections from the panels will be connected directly to the cables pre-installed on the ProStar controller - positive (+) to negative (-).

NOTE : To keep the pole from turning in the wind, we suggest you cut at least two pieces of re-bar at lengths equal to the full diameter of the hole. Weld re-bar (or drill holes and insert through pipe) to the underground portion of the pipe so that the pieces of re-bar are perpendicular to each other and remain parallel to the ground. When the mounting pole is installed, the re-bar will protrude radially outward into the concrete foundation.

INSTALLATION procedure

PLEASE READ ALL INSTRUCTIONS CAREFULLY PRIOR TO INSTALLING YOUR LAKE BED AERATION SYSTEM.

CAUTION : It is dangerous to work in and around open water. Please wear safety equipment when using tools, shovels, etc. and be sure to wear a life vest while operating a boat. Be careful of ice covered lakes in the winter, aeration systems weaken the ice and it is never safe to walk on aerated lakes.

CABINET/DIFFUSERS

1 Open the lid and inspect all equipment to ensure no evident damage has occurred during shipping. You will find all necessary installation hardware enclosed within the cabinet or in a separate package that was shipped with this unit.

2 Your cabinet is 100% recycled plastic and is designed to be mounted on the provided legs. Make sure the system is level and firmly sitting on all four (4) legs. Systems can either be placed on a Level-aer Equipment Pad, concrete pad, concrete blocks or mounted directly on the ground. Systems can be fastened down so they are securely in place, but the Owner must provide all hardware.

3 Alpine Self-Weighted tubing requires no additional weight and will sink gently to the bottom by itself. Stainless steel hose clamps and tubing couplers are provided for splicing tubing together and attaching the tubing to the Aeration Unit as well as the diffuser(s).

4 Connect the Alpine tubing to the airline from the compressor housing. Put the roll of tubing in the boat. As you proceed to the desired diffuser location, feed the tubing over the side of the boat. When you reach the desired diffuser location, connect the Alpine tubing to the diffuser inlet, secure with stainless steel clamp and lower it into place.

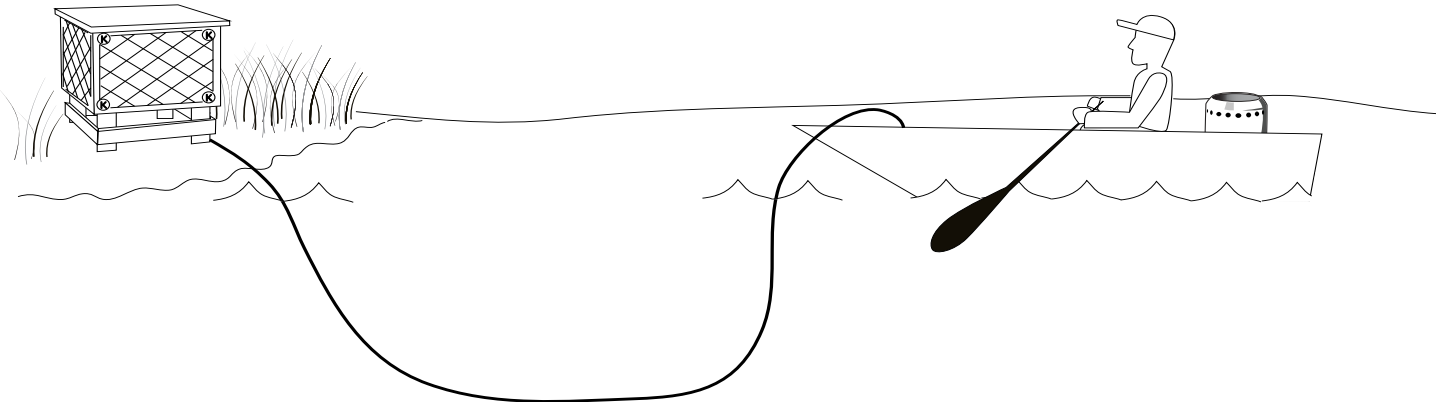

5 Start Up: After connecting the battery (page 5) and the solar panel (page 3) the system is now ready for start up. Again, make sure the valves on the manifold are fully opened. The timer has been pre-set for you, but see page 7 for proper timer use. The compressor and cooling fan should turn on. It will take a little time before air can be seen bubbling up from the diffusers. Let the system run with the valves fully open for a few minutes, then visually inspect the diffuser locations to ensure each diffuser is operating.

6 Diffuser Adjustment: You will most likely need to adjust the airflow to each diffuser. Some diffusers may be receiving more air than the others, this valve will need to be closed down a little to increase the flow to the remaining diffusers. Continue this process until each of the diffusers receives approximately the same amount of airflow.

SOLAR controller

THE BATTERY MUST BE CONNECTED PRIOR TO STARTING THE SYSTEM. PLEASE READ ALL INSTRUCTIONS CAREFULLY PRIOR TO INSTALLING YOUR LAKE BED AERATION SYSTEM.

battery CONNECTION

Use Diagram to the right for help.

Connect the negative terminal of battery A to the positive terminal of battery B using the BLUE Jumper Connection. This creates a 24V battery.

A positive (RED) and a negative (BLACK) lead have already been connected to the ProStar and are ready to be connected to the positive and negative terminals on the batteries. Be sure to attach the positive lead (RED) to the positive terminal on battery A and the negative lead (BLACK) to the negative terminal on battery B. Observe that the Battery Status LEDs blink in sequence one time. Torque all the ProStar terminals tightly, but do not exceed 35 in.-lb. Solar panel input has already been connected to the ProStar. With sunlight, the green Charging LED will light.

*BATTERY TYPE is pre-set for Type 1 - Gel.

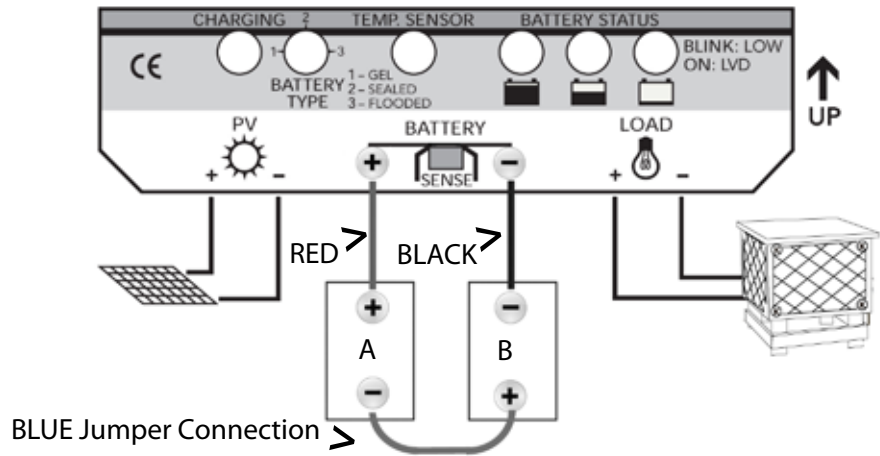

LED indicators

CHARGING (LED 1 - GREEN)

ON: battery charging during sunlight (always on during sunlight)
OFF: normal during night (off during sunlight indicates solar reverse polarity or overcurrent)

BATTERY STATUS (LEDS 2 – 4)

GREEN: ON indicates battery is near full charge
GREEN: BLINKING indicates PWM charging (regulation)
YELLOW: ON indicates battery at middle capacity
RED: BLINKING indicates a low charge state and a low voltage load disconnect (LVD) warning
RED: ON indicates the load has been disconnected (LVD)

FAULT INDICATIONS (G = green; Y = yellow; R = red)

G/Y/R blinking together – battery select fault
R – Y sequencing – high temperature disconnect
R – G sequencing – high voltage disconnect
R/G – Y sequencing – load short circuit or overload

LOAD OFF: A brief push of the button (less than 2 seconds) will disconnect the Load. The Solar remains on and charging.

LOAD AND SOLAR OFF: If the button is held down for 2 seconds, the Solar will also be disconnected.

SAFETY INFORMATION :

- Be very careful when working with batteries. Wear eye protection. Have fresh water available to wash and clean any contact with battery acid.
- Charge only lead-acid batteries that are properly sized for the system.
- Explosive battery gasses can be present during charging. Be certain there is enough ventilation to release the gasses.
- Use insulated tools and avoid metal objects near the batteries.
- Carefully read the battery manuals and other equipment manuals before installing the solar system. Observe ALL precautions when working with batteries and power electronics.
- Fuses or DC disconnects may be required in the system. These protective devices are not part of the solar controller.
- Avoid large voltage drops in the battery wires. Use the Battery Sense connection (see diagram) for best battery charging and system performance.
- Do not allow water to enter the controller.
- Avoid touching the controller heat sink. Under certain operating conditions, the heat sink can become hot.
- Install the controller in a vertical position with adequate space for ventilation.
- Ensure that the system is properly grounded.

NOTE : Batteries provided are AGM style, not lead-acid.

SOLAR controller

SELF-DIAGNOSTICS (SELF-TEST)

If the push button is held down for 4 seconds, the ProStar will go into automatic self-diagnostics. Note that the button must be released to start the self-test.

NOTE: The push button can be used to toggle through the displays faster. The entire self-test takes 30 to 45 seconds. The load will be turned on for 0.1 second and may flash during the test. A short or overload condition could cause a controller restart. The following displays will occur (examples are used):

0.0.0 - self-test started, checking the digital meter segments
12v - the system voltage (12/24/48)
15A - current rating
r1.5 - software version installed
E04 - a fault has been detected (see list below)
--- display if no fault is found
25c - temperature measured at the controller
rP - remote temp probe is detected (if connected)
25c - temperature at the remote probe (if connected)

SEn - battery sense detected (if connected)
S-1 - battery select position (1,2, or 3)
J-1 - telecom noise jumper cut (change to on-off regulation)
end of the self-test
End --- End - display continues if no error was detected.
End End - display continues if an error has been detected.

MANUAL DISCONNECT

A precision 3-digit digital meter will continuously display battery voltage, solar current, and the load current. The meter automatically scrolls through these 3 displays. The 3 red LEDs will indicate which parameter is being displayed.

DIGITAL DISPLAY

Lvd - LVD - low voltage load disconnect (load only)
Hvd - high voltage disconnect (both solar and load)
Hot - high temperature disconnect (both solar and load)
OCP - overcurrent and short circuit protection (load, solar overcurrent)
0.0 - short circuit protection (solar only)

To terminate the self-test, push the button. The self-test can be repeated to confirm the result.

ERROR LIST:

E01 - Rotary switch battery selection failure
E03 - Voltage reference test failed (circuit, malfunctions)
E04 - Solar array current fault (circuit, FETs [Field-Effect Transistor])
E07 - Load FETs off test (load connection, FETs shorted)
E08 - Load current fault (circuit, FETs)
E09 - Load FETs on test (load circuit, FETs open)
E10 - Internal temp sensor out of range high
E11 - Internal temp sensor out of range low
E12 - Remote temp probe out of range
E13 - Battery sense fault (battery V drop over 5V, no Sense negative connection)

BATTERY CHARGING INFORMATION

The ProStar uses 4 stages of charging for rapid, efficient and safe battery charging. These are shown in the diagram to the right:

1. Recharging with 100% of available solar energy.
2. PWM constant-voltage regulation to prevent heating and excessive battery gassing. Pulse charging to restore full battery capacity.
3. Float: After battery is fully recharged, ProStar reduces to a float or trickle charge.

The transition depends on battery history. A load that exceeds available solar output will return ProStar to the PWM mode.

4. Equalize: A boost charge that depends on elapsed time and battery history. Flooded cells receive a vigorous equalization, sealed batteries a smaller boost to bring uneven cells into balance and extend the battery life. Gel cells are not equalized.

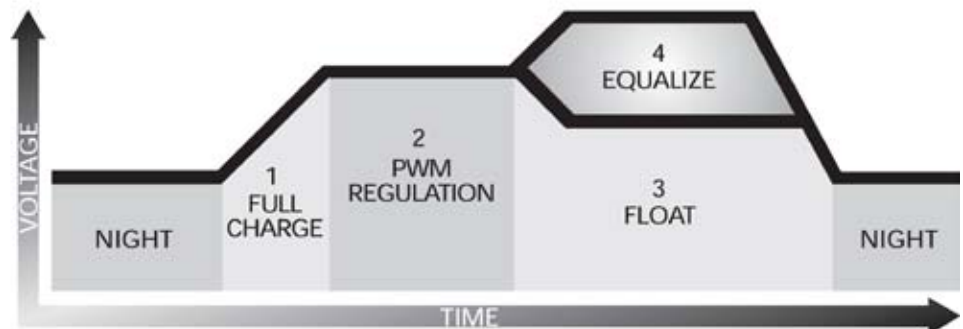

THE timer

NOTE:

All timers are pre-set on your Solaer Aeration System to run 20 hours, 2:00 p.m. to 10:00 a.m. This is our recommended time of use. Use the below information if you would like to increase or decrease according to the vitality of your pond or lake.



1 SETTING THE TIMER:

- Set the "RUN" switch to the  button.
- Push the "1...7" button to set the day (Ex: Sunday = 1, Monday = 2, Etc.)
- Use the "h" and "m" buttons to set the current time (Ex: 12:41 PM)
- Slide "RUN" switch back to the CENTER position (SEE A).

C



2 SETTING THE ON AND OFF CYCLES:

- Set the "RUN" switch to the RIGHT position
- Set the number of run days (1-7).
Press the "1...7" button until all arrows are lit for each day of the week.
- Use the "h" and "m" buttons to set the "On" time. A light bulb will be visible on the display (SEE B).
- Press the  button to set the "Off" time. Please note that the number in the bottom right hand side of the display will change from 1 to 2. Also, no light bulb will be displayed.
- Set the number of run days (1-7). Press the "1...7" button until all arrows are lit for each day of the week (SEE C).
- Use the "h" and "m" buttons to set the "Off" time.
- Slide the Run switch back to the center position.



3 RESET TIMER:

- If program is not working correctly, press and hold down the "R" button.
- Repeat steps 1 and 2.

COMPRESSOR maintenance

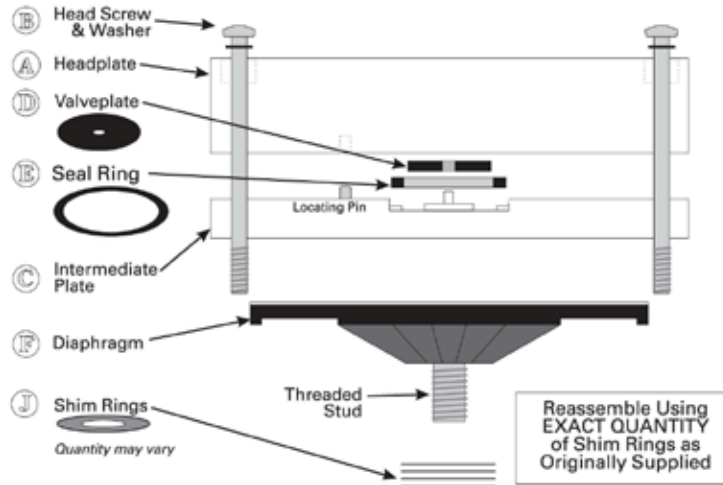

- A** : Headplate
- B** : Head Screws (4 per head)
- C** : Intermediate Plate
- D** : Valveplate (2 per head)
- E** : Seal Ring (2 per head)
- F** : Diaphragm
- G** : Shim Rings (Qty may vary)

*Drawing is for reference only, and covers a variety of models. Use the same quantity of parts as originally supplied on your pump.

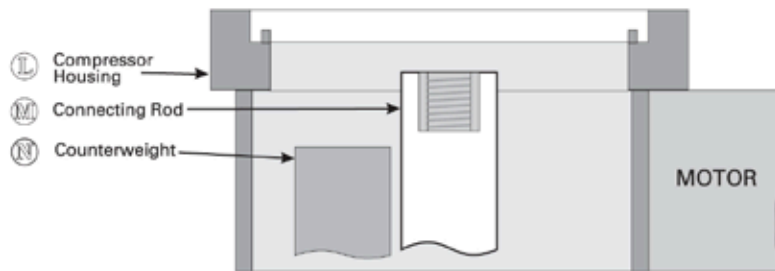

changing the diaphragm & valve plate

HEAD ORIENTATION MAY DIFFER FROM ABOVE.

equipment

Proper replacement kit, Felt tip marking pen
Tools Required: Phillips head screwdriver

procedure

1. Disconnect the pump from electrical power. Make a sketch of the position of any tubes and fittings for ease of reassembly later. Remove interconnecting tubing only where necessary.

2. Mark the position of the pump head plate **A**, intermediate plate **C** and crankcase **L** relative to each other by drawing a line on the edges with a pencil or other marker to assure proper reassembly. To access the counterweight **N**, remove the screws holding the compressor cover. Retain any gasketing for reuse.

3. Remove the four screws and washers **B** and remove the headplate **A**. Note the positioning of the valveplates **D** and seal rings **E** in relation to the valve ports on the headplate **A** and intermediate plate **C**. Lift off the seal rings and valveplates.

4. Remove the intermediate plate **C**.

Carefully clean the head and intermediate plates of any residue using fine steel wool. **DO NOT** scratch the parts.

5. Unscrew the old diaphragm **F** by turning it counterclockwise using both hands. **DO NOT** use tools! **IMPORTANT** — Take care not to lose any small parts such as the shim rings **J**, positioned between the diaphragm stud and connecting rod, as they must be replaced for proper pump operation. Quantity and type of parts may vary among models. Parts removed must be replaced exactly as found.

6. Place the parts removed in step 5 onto the threaded stud of the new diaphragm. Carefully screw the new diaphragm **F** into the connecting rod **C**. Tighten firmly using both hands only - **DO NOT** use tools!

TIP: If possible, hold the pump with the motor shaft vertical when starting the threaded diaphragm stud into the connecting rod.

7. Turn the counterweight **N** until the diaphragm is flat across. Carefully center the diaphragm over the compressor housing **L**, firmly seating the diaphragm edge into housing groove.

8. Place the clean intermediate plate **C** onto the compressor housing **L**, according to your

previously drawn markings, then place the new valve plates **D** and seal rings **E** on top of the intermediate plate. Make sure the seal rings are properly seated in intermediate plate recesses to avoid pinching.

9. Place the clean headplate **A** on top of the intermediate plate **C** according to your previously drawn markings and the locating pin. Then tighten the four screws **B** in a criss-cross pattern. Do not overtighten. Turn the counterweight or the fan by hand to ensure that the pump turns freely.

10. Replace the compressor housing cover. On portable models, replace the cabinet.

11. Remove any old Teflon® tape from all fittings. Carefully apply two layers of Teflon® tape around any fittings before reinstalling into the pump head. Install any tubing and fittings as previously sketched in step 1 above.

Do not apply tape beyond threads, as excess tape may tear off and lodge in the valves. Do not substitute any other type of tape.

warranty

Keeton Industries finished products, when properly installed and operated under normal conditions of use, are warranted by Keeton Industries to be free from defects in material and workmanship for a period of twenty-four (24) months from the date of purchase from Keeton Industries or an authorized Keeton Industries Representative or Dealer. In order to obtain performance under this warranty, the buyer must promptly (in no event later than thirty (30) days after discovery of the defect) give written notice of the defect to Keeton Industries, 1520 Aquatic Drive, Wellington, CO 80549, or an authorized Service Center. Buyer is responsible for freight charges both to and from Keeton Industries in all cases.

Keeton Industries' warranties also do not extend to any goods or parts which have been subjected to misuse, lack of maintenance, neglect, damage by accident or transit damage.

THIS EXPRESS WARRANTY EXCLUDES ALL OTHER WARRANTIES OR REPRESENTATIONS EXPRESSED OR IMPLIED BY ANY LITERATURE, DATA, OR PERSON. KEETON INDUSTRIES MAXIMUM LIABILITY UNDER THIS EXCLUSIVE REMEDY SHALL NEVER EXCEED THE COST OF THE SUBJECT PRODUCT AND KEETON INDUSTRIES RESERVES THE RIGHT, AT ITS SOLE DISCRETION, TO REFUND THE PURCHASE PRICE IN LIEU OF REPAIR OR REPLACEMENT.

KEETON INDUSTRIES WILL NOT BE RESPONSIBLE OR LIABLE FOR INDIRECT OR CONSEQUENTIAL DAMAGES OF ANY KIND, however arising, including but not limited to those for use of any products, loss of time, inconvenience, lost profit, labor charges, or other incidental or consequential damages with respect to persons, business, or property, whether as a result of breach of warranty, negligence or otherwise. Notwithstanding any other provision of this warranty, BUYER'S REMEDY AGAINST KEETON INDUSTRIES FOR GOODS SUPPLIED OR FOR NON-DELIVERED GOODS OR FAILURE TO FURNISH GOODS, WHETHER OR NOT BASED ON NEGLIGENCE, STRICT LIABILITY OR BREACH OF EXPRESS OR IMPLIED WARRANTY IS LIMITED SOLELY, AT KEETON INDUSTRIES' OPTION, TO REPLACEMENT OF OR CURE OF SUCH NONCONFORMING OR NON-DELIVERED GOODS OR RETURN OF THE PURCHASE PRICE FOR SUCH GOODS AND IN NO EVENT SHALL EXCEED THE PRICE OR CHARGE FOR SUCH GOODS. KEETON INDUSTRIES EXPRESSLY DISCLAIMS ANY WARRANTY OF MERCHANTABILITY OR FITNESS FOR A PARTICULAR USE OR PURPOSE WITH RESPECT TO THE GOODS SOLD. THERE ARE NO WARRANTIES WHICH EXTEND BEYOND THE DESCRIPTIONS SET FORTH IN THIS WARRANTY, notwithstanding any knowledge of Keeton Industries regarding the use or uses intended to be made of goods, proposed changes or additions to goods, or any assistance or suggestions that may have been made by Keeton Industries personnel.

Unauthorized extensions of warranties by the customer/dealer shall remain the customer's/dealer's responsibility.

DURAPLATE DIFFUSERS ARE COVERED BY A SEPERATE LIFE TIME WARRANTY AGAINST MATERIAL DEFECTS OR CRAFTSMANSHIP.

This warranty can be modified only by authorized Keeton Industries personnel by signing a specific, written description of any modifications.

troubleshooting

	Low Pressure	High Pressure	Pump Overheat	Won't Start	Excess Noise	REASON & REMEDY
COMPRESSOR	•		•	•		Filter dirty. Clean or replace.
	•					Valves closed. Clean or replace.
	•					Worn cup. Repair or replace.
		•	•	•		Relief valve set too high. Inspect and adjust.
	•					Relief valve set too low. Inspect and adjust.
	•	•	•	•		Plugged pressure line. Inspect and repair.
			•	•		Low voltage, won't start. Check power source.
			•	•	•	Voltage wrong. Check power source.
	•				•	Worn diaphragm hitting cylinder. Replace.
			•		•	Cylinder misadjustment. Realign.
	•			•		Leaky hose or check valve. Replace.
	•		•	•	•	Dirt or liquid on top of diaphragm. Inspect and clean.
				•		Timer set incorrectly. Inspect and adjust.
		•	•		Worn cooling fan. Clean or replace.	
DIFFUSERS	Uneven Air Flow	High Air Flow	Low Air Flow	Won't Start	"Burping" Bubbles	REASON & REMEDY
	•		•	•		Leak in System. Check all connections and tubing and repair.
	•	•	•	•		Manifold not set correctly. Inspect and adjust.
			•	•		Compressor Issue. See above.
					•	Damaged or torn Membrane. Replace.
	•					Unbalanced Manifold. Inspect and adjust.

...still having troubles? Contact us:

800.493.4831 or info@keetonaquatics.com



Based in Wellington Colorado, Keeton Industries, Inc. is a family-owned and operated aquatics manufacturing company. Since its founding in 1972, Keeton Industries continues to promote naturally healthy aquatic habitats, lakes, fisheries and wastewater facilities. We create and develop the best technology and equipment available to improve the environment and benefit the world's population. Our innovative aeration system designs and eco-friendly beneficial microbe technology continue to keep us at the forefront of our industry.

Our focus at Keeton Industries is to provide you, our customers, with quality products, excellent service, comprehensive technical support and cost-effective solutions.

| BENEFICIAL MICROBES | ELECTRIC & SOLAR AERATION SYSTEMS |



© 2011 Keeton Industries, Inc. All rights reserved.

Other Ponds And Lakes Are Green With Envy® is a registered trademark and Solaer™, Duraplate™, Alpine™ Tubing and Quiet Line™ are trademarks of Keeton Industries, Inc. The Solaer Lake Bed Aeration Systems are protected by United States Patent No. 6,676,837.

OTHER PONDS AND LAKES ARE GREEN WITH ENVY™

1520 Aquatic Drive, Wellington CO 80549 • KeetonAquatics.com • toll-free: 800.493.4831 • fax: 970.568.7795