



SB-1 & SB-2



The Keeton Industries Solaer series of solar powered lake bed aeration systems are the ideal choice for remote ponds and lakes where power is not available or for an environmentally conscience solution. The SB-1 and SB-2 are effective in aerating ponds and lakes up to 2 surface acres in size. These systems come complete with a high efficacy solar panel, charge control system, battery back-up, EcoFlow energy efficient compressor, high volume cooling fans, programmable digital timer and a fully adjustable aluminum manifold housed in attractive, 100% recycled plastic cabinet. Duraplate self-cleaning, non-clogging membrane diffusers emit millions of tiny bubbles that increase dissolved oxygen levels while eliminating stratification, improving water quality and clarity. Like all of our aeration systems, the Solaer series are backed by a full 2 year warranty.

SPECS/INCLUSIONS

THE TUBING



- Self-weighted
- 1/2" I.D. with 1/4" sidewalls
- Fishhook resistant
- Will not kink or break
- Available in 100' and 500' lengths
- 15 year warranty

THE DIFFUSER



- Self-cleaning
- Non-clogging
- Self-weighted
- Fishhook resistant
- High Oxygen transfer
- Lifetime warranty



Shown with Level-aer Equipment Pad - additional upgrade.

THE CABINET

- Attractive, 100% recycled plastic cabinet
- 20"W x 24"L x 27"T
- 24V high efficacy solar panel
- Top pole mount
- Charge control system
- 3 day battery back-up
- EcoFlow 24V compressor
- 37cfm cooling blower
- Sound reduction package
- 1" ASTM certified Acoustical Foam
- Programmable digital timer
- 2-valve adjustable aluminum manifold

Model	Feature
SB-1	1 Diffuser
SB-1B	1 Diffusers & 100' of Tubing
SB-2	2 Diffusers
SB-2B	2 Diffusers & 200' of Tubing



SB-1 & SB-2

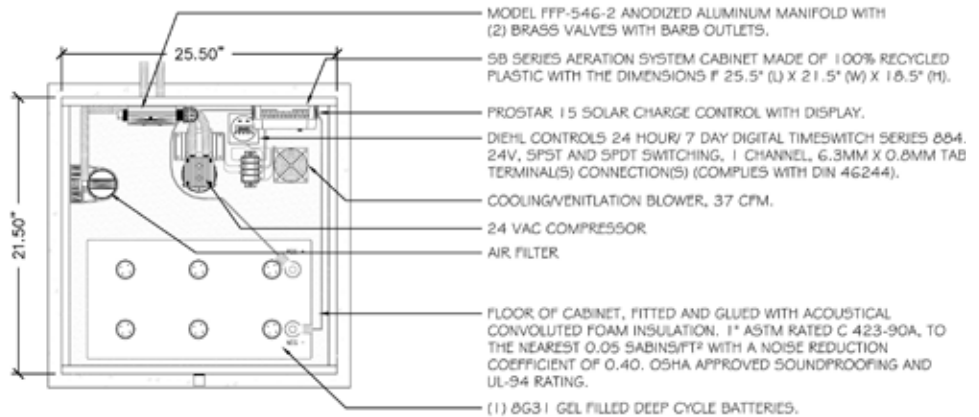
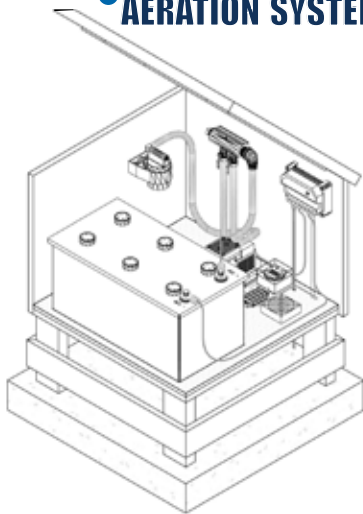

TOP VIEW
NOT TO SCALE

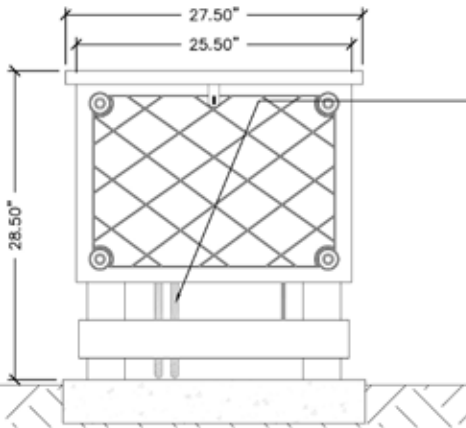

FRONT VIEW
NOT TO SCALE

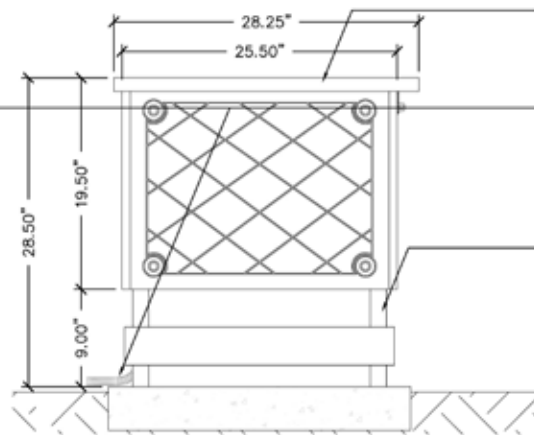

SIDE VIEW
NOT TO SCALE

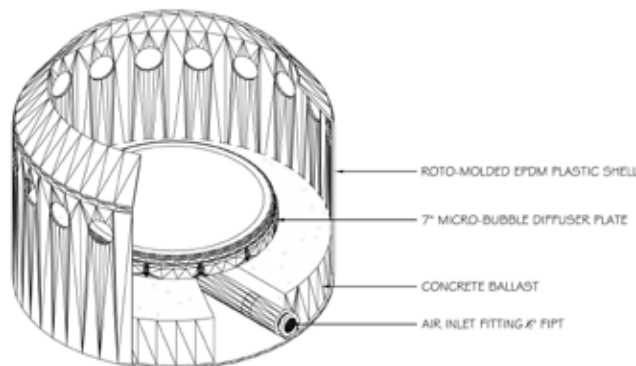

**DURAPLATE DIFFUSER
DDP-7 - CUT VIEW**
NOT TO SCALE

CAD Drawings Available

© 2011 Keeton Industries. All rights reserved.
Other Ponds And Lakes Are Green With Envy™ is a registered trademark and Solaer™ and Duraplate™ are trademarks of Keeton Industries, Inc. The Solaer Lake Bed Aeration Systems are protected by United States Patent No. 6,676,837.



OTHER PONDS AND LAKES ARE GREEN WITH ENVY™

1520 Aquatic Drive, Wellington CO 80549 • KeetonAquatics.com • toll-free: 800.493.4831 • fax: 970.568.7795