



AERATION SYSTEMS

DR SERIES manual



 **KEETON**
INDUSTRIES

OTHER PONDS AND LAKES ARE GREEN WITH ENVY™

1520 Aquatic Drive, Wellington CO 80549 • KeetonAquatics.com • toll-free: 800.493.4831 • fax: 970.568.7795

congratulations!

Dear Valued Customer,

Congratulations on your purchase of a Keeton Industries Lake Bed Aeration System! In the following pages you will find detailed information about the system you have purchased. These include a system checklist, installation instructions, required maintenance, warranty information and much more.

Please read through this content and familiarize yourself with your new system and how it works.

All our best,
Keeton Industries

IMPORTANT

This equipment was thoroughly inspected and carefully packaged in our facility. Upon acceptance by the carrier (UPS, USPS, Motor Freight or Other) they assume responsibility for the goods in transit and their ultimate safe arrival. Should you receive your shipment in a damaged condition, either apparent or concealed; a damage claim must be made by you, the customer, directly with the shipping carrier. Keeton Industries cannot make this claim for you.

APPARENT LOSS or damage

Should visual inspection upon receipt of goods show loss or damage, it must be noted on the freight bill, express receipt, or UPS drivers record and signed by the driver or agent. Failure to do so will result in the carrier refusing to honor your damage claim. The carrier will furnish you the necessary form(s) for filing a claim should they be needed.

CONCEALED damage

When damage is not apparent until the equipment is unpacked, a claim for concealed damage is to be made to the carrier. When damage is discovered, make a written or phone request to the carrier for inspection. You must make this request for inspection **within forty-eight (48) hours** of delivery. Immediately inspect all packages for exterior and interior damage upon receipt and make any claims as soon as possible. Keep all cartons and packaging material to show the inspector. The carrier will furnish you with an inspection report and necessary forms for filling a concealed damage claim, since such damage is the carrier's responsibility.

RETURNS

If you are unhappy with your order for any reason, Keeton Industries will gladly exchange items; issue credit or refund the purchase price to you (less restocking charges) within 7 days of receiving the product. In all cases, return freight costs are the responsibility of the customer.

Please call or write for Return Authorization Number so that we may handle your return as quickly and efficiently as possible. We will not accept any returned merchandise without a Return Authorization number being displayed on the package.

NOTICE

There are no returns on Custom Designed equipment or Manufactured equipment for specific applications.

SYSTEM checklist

INSIDE THE 100% RECYCLED PLASTIC CABINET:

PROGRAMMABLE DIGITAL TIMER: Controls on/off function. (See p.4)

ADJUSTABLE MANIFOLDS: Allows airflow to be adjusted to the diffusers.

ROCKING PISTON COMPRESSORS: 1/3 Horse Power generates compressed air.

AIR INTAKE FILTER: Prevents dust and dirt from damaging the compressor.

ACOUSTICAL SOUND PROOF FOAM: Keeps system "quiet".

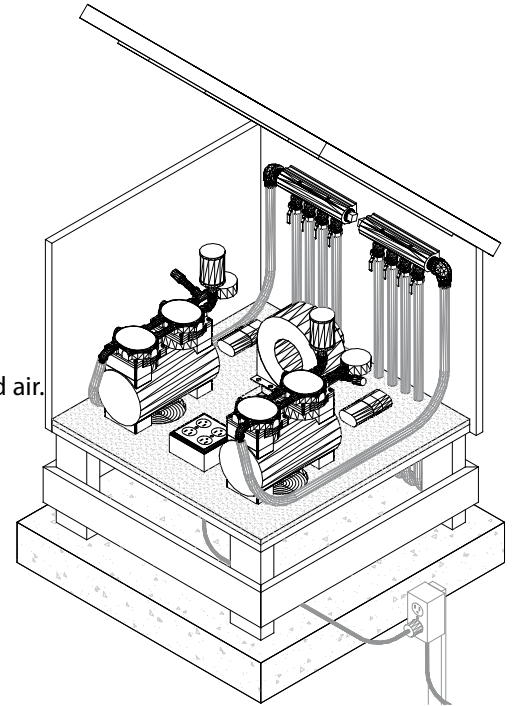

Shown with Level-aer
Equipment Pad
– additional upgrade.

THE CABINET

Our 100% recycled plastic cabinets, acoustical foam and sound dampening isolators work to eliminate escaping sound. The high capacity cooling blower works to maintain proper temperatures for optimum performance even in the most inhospitable locations. A digital timer offers flexibility and allows the system to run during certain times, such as at night only. The systems also include a fully adjustable aluminum distribution manifold.

Our aeration systems use Duraplate™ self-cleaning, non-clogging membrane diffusers. The Duraplate diffuser is designed to create a large amount of laminar circulation to eliminate stratification. The Duraplate diffusers also offer a very high oxygen transfer rate to increase dissolved oxygen levels at all levels in the pond from the surface to the bottom. Due to their design, the Duraplate diffusers will not need to be removed for cleaning and are backed by a lifetime warranty. The rotationally molded Duraplate diffuser shell is also fishhook resistant, making them an ideal choice for fishing ponds and lakes.

THE DIFFUSERS



THE TUBING

Keeton Industries Alpine™ self-weighted feeder tubing offers the perfect balance of flexibility and weight. Alpine tubing sinks directly to the bottom and will not kink or break. Alpine tubing is a high density, flexible tubing that features a thick, 1/4" sidewall. Available in 100' rolls and 500' reels.

INSTALLATION procedure

equipment



SCREW DRIVER



TUBING CUTTER



WRENCH

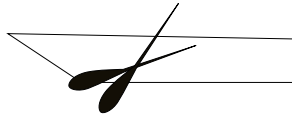

A BOAT WITH MOTOR OR OARS



SHOVEL

PLEASE READ ALL INSTRUCTIONS CAREFULLY PRIOR TO INSTALLING YOUR LAKE BED AERATION SYSTEM.

CAUTION : It is dangerous to work in and around open water. Please wear safety equipment when using tools, shovels, etc. and be sure to wear a life vest while operating a boat. Be careful of ice covered lakes in the winter, aeration systems weaken the ice and it is never safe to walk on aerated lakes.

1 Open the lid and inspect all equipment to ensure no evident damage has occurred during shipping. You will find all necessary installation hardware enclosed within the cabinet or in a separate package that was shipped with this unit. Your cabinet is either 100% recycled plastic.

2 All Cabinets are designed to be mounted on the provided legs. Make sure the system is level and firmly sitting on all four (4) legs. Systems can either be placed on a Level-are Equipment Pad, concrete pad, concrete blocks or mounted directly on the ground. Systems can be fastened down so they are securely in place, but the Owner must provide all hardware.

3 Alpine Self-Weighted tubing requires no additional weight and will sink gently to the bottom by itself. Stainless steel hose clamps and tubing couplers are provided for splicing tubing together and attaching the tubing to the Aeration Unit as well as the diffuser(s).

4 Connect the Alpine tubing to the airline from the compressor housing. Put the roll of tubing in the boat. As you proceed to the desired diffuser location, feed the tubing over the side of the boat. When you reach the desired diffuser location, connect the Alpine tubing to the diffuser inlet, secure with stainless steel clamp and lower it into place with rope and float provided.

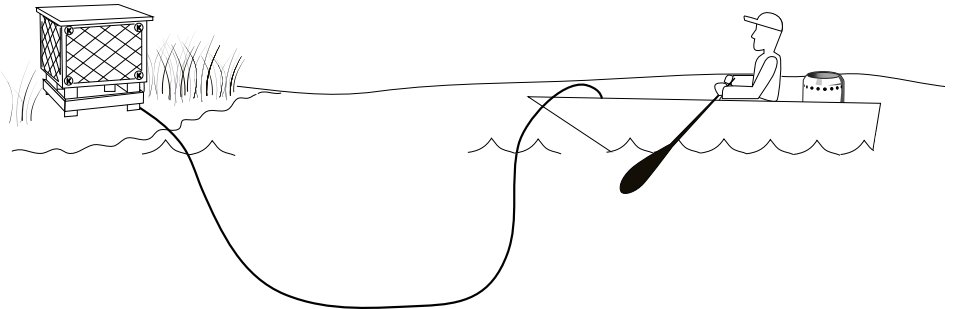

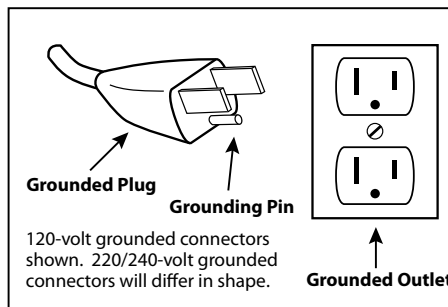

5 Electrical Hookup: After the cabinet has been set in place and the feeder tubing and diffuser have been installed the system is ready to have the electricity hooked up. Make sure all valves inside the cabinet are wide open and the timer is placed in the off position. Most systems will come with a standard electrical plug (120V/60Hz units) and can be plugged into any electrical outlet with GFCI protection. All other systems will require a Professional Electrician to power the system (Provided by the Owner). Once the system is hooked up to electrical power it is now ready for start up.

Minimum gage for extension cords											
Amps	Volts		Length of cord in feet								
	120v	240v	25	50	100	150	200	250	300	400	500
0-2			18	18	18	16	16	14	14	12	12
2-3			18	18	16	14	14	12	12	10	10
3-4			18	18	16	14	12	12	10	10	8
4-5			18	18	14	12	12	10	10	8	8
5-6			18	16	14	12	10	10	8	8	8
6-8			18	16	12	10	10	8	6	6	6
8-10			18	14	12	10	8	8	6	6	4
10-12			16	14	10	8	8	6	6	4	4
12-14			16	12	10	8	6	6	6	4	2
14-16			16	12	10	8	6	6	4	4	2
16-18			14	12	8	8	6	4	4	2	2
18-20			14	12	8	6	6	4	4	2	2



6 Start Up: The system is now ready for start up. Again make sure the valves on the manifold are fully opened. The system can now be started. See timer instructions in Steps 8-10, for proper use. The compressor and cooling fan should turn on. It will take a little time before air can be seen bubbling up from the diffusers. Let the system run with the valves fully open for a few minutes, then visually inspect the diffuser locations to ensure each diffuser is operating.

7 Diffuser Adjustment: You will most likely need to adjust the airflow to each diffuser. Some diffusers may be receiving more air than the others, this valve will need to be closed down a little to increase the flow to the remaining diffusers. Continue this process until each of the diffusers receives approximately the same amount of airflow. Every system includes a pressure gauge, this gauge will help you monitor the system pressure. The system **does not** need to be set, the running pressure is dependant upon the water depth and the length of tubing runs. Most systems balance out at around 6 to 12psi. In case of over pressuring, each system includes an automatic pressure relief valve that has been preset by our technicians. Do not adjust this valve without consulting Keeton Industries first. This valve will bleed off any excess pressure; this will protect your compressor from over pressuring.

! WARNING	
	
Electrical Shock Hazard	
Disconnect electrical power supply cord before installing Service Kit.	
If product is hard wired into system, disconnect electrical power at the circuit breaker or fuse box before installing Service Kit.	
Vent all air lines to release pressure.	
Failure to follow these instructions can result in death, fire or electrical shock.	



- 8** **SETTING THE TIMER:**
- Set the "RUN" switch to the LEFT position
 - Push the "1...7" button to set the day (SEE A) (Ex: Sunday = 1, Monday = 2, Etc.)
 - Use the "h" and "m" buttons to set the current time (Ex: 12:41 PM)
 - Slide "RUN" switch back to the CENTER position.

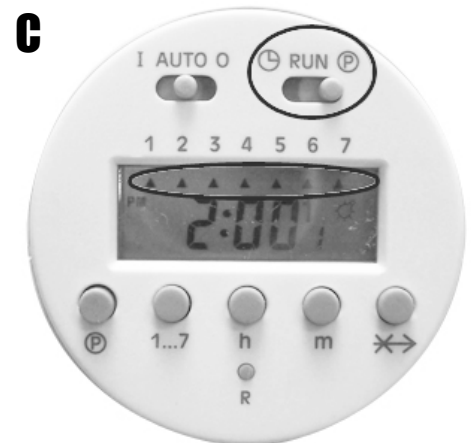

- 9** **SETTING THE ON AND OFF CYCLES:**
- Set the "RUN" switch to the RIGHT position
 - Set the number of run days (1-7). Press the "1...7" button until all arrows are lit for each day of the week.
 - Use the "h" and "m" buttons to set the "On" time. A light bulb will be visible on the display. (SEE B)
 - Press the **P** button to set the "Off" time. Please note that the number in the bottom right hand side of the display will change from 1 to 2. Also, no light bulb will be displayed.
 - Set the number of run days (1-7). Press the "1...7" button until all arrows are lit for each day of the week.



- 10** **RESET TIMER:**
- If program is not working correctly, press and hold down the "R" button.
 - Repeat steps 8 and 9.

CONGRATULATIONS ON COMPLETION!

Your Installation is now complete. If you have any problems, see "TROUBLESHOOTING" on the back page. If you have questions or concerns please feel free to contact us at 800.463.4831. Our professional staff will be more than happy to help you with any problems you may be experiencing.

COMPRESSOR maintenance

On a monthly basis you should check the system to ensure it is functioning properly. This monthly check up should include checking that air inlet filters are not dirty and restricting airflow, making sure the cooling fan is working properly and the air intake vents are not plugged with debris. Filters should be cleaned or replaced when they become soiled and air intake vents need to have all debris removed to allow unrestricted airflow. System failure is almost always a result of the compressor overheating due to clogged inlet filters and/or air intake vents or cooling fan failure.

Every twelve (12) to sixteen (16) months the compressors should have a repair kit installed. This is a fairly simple process that usually takes about an hour to complete. If you're not very mechanically inclined it might be best to have a service professional do this for you. This process usually involves changing gaskets, seals, piston sleeves and filters. This will eliminate much of the day to day wear and tear your compressors will experience and will greatly extend their service life. Every repair kit comes with its own set of instructions for proper servicing. If you feel you are not able to perform these duties on your own you can send your compressors into Keeton Industries for maintenance or repair. When performing compressor maintenance, order item# QLR, which includes Service Kit K797 as well as (2) AT275 - cylinder sleeves for complete compressor rebuild.

REF	DESCRIPTION	QTY	75R6
1	CAP SCREW	4	BB516C
2	CAP SCREW	4	BB570
3	HEAD	1	AP200A
4 Δ	HEAD O-RING	2	AP201A
5	VALVE LIMITER	2	AP110
6 Δ	LEAF VALVE	4	AF817
7	VALVE PLATE	2	AP101A
8	VALVE RETAINER	2	AF819A
9	VALVE SCREW	2	BB330A
10 Δ	CYLINDER O-RING	2	AT276
11 Δ	CYLINDER	2	AP275
12 Δ	RETAINER SCREW	4	AT283
13	RETAINER PLATE	2	AT566A
14 Δ	PISTON CUP	2	AT280
15	FAN	1	AP108A
15A	FAN - LEAD END	1	AP108
16	GRILLE SHROUD	1	AP107
17 Δ	O-RING	4	AK846
18	TUBE	2	AP125A
19	VALVE PLATE ASSEMBLY	2	AP102A
***	COMPRESSOR REPAIR KIT	1	QLR

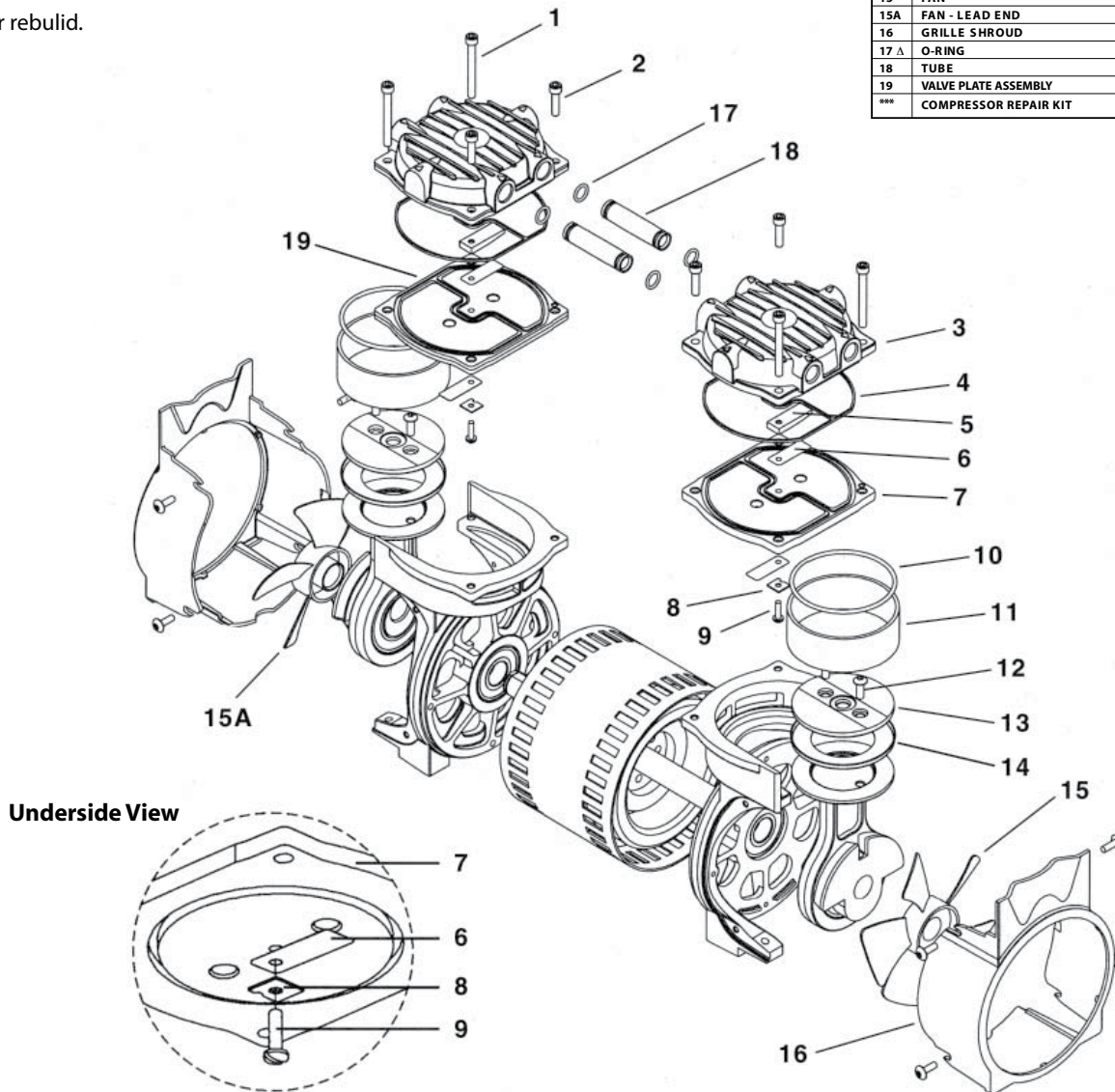

* 75R shown.

*** Item not shown.

Δ Denotes parts included in the Compressor Service Kit (QLR).

warranty

Keeton Industries finished products, when properly installed and operated under normal conditions of use, are warranted by Keeton Industries to be free from defects in material and workmanship for a period of twenty-four (24) months from the date of purchase from Keeton Industries or an authorized Keeton Industries Representative or Dealer. In order to obtain performance under this warranty, the buyer must promptly (in no event later than thirty (30) days after discovery of the defect) give written notice of the defect to Keeton Industries, 1520 Aquatic Drive, Wellington, CO 80549, or an authorized Service Center. Buyer is responsible for freight charges both to and from Keeton Industries in all cases.

Keeton Industries' warranties also do not extend to any goods or parts which have been subjected to misuse, lack of maintenance, neglect, damage by accident or transit damage.

THIS EXPRESS WARRANTY EXCLUDES ALL OTHER WARRANTIES OR REPRESENTATIONS EXPRESSED OR IMPLIED BY ANY LITERATURE, DATA, OR PERSON. KEETON INDUSTRIES MAXIMUM LIABILITY UNDER THIS EXCLUSIVE REMEDY SHALL NEVER EXCEED THE COST OF THE SUBJECT PRODUCT AND KEETON INDUSTRIES RESERVES THE RIGHT, AT ITS SOLE DISCRETION, TO REFUND THE PURCHASE PRICE IN LIEU OF REPAIR OR REPLACEMENT.

KEETON INDUSTRIES WILL NOT BE RESPONSIBLE OR LIABLE FOR INDIRECT OR CONSEQUENTIAL DAMAGES OF ANY KIND, however arising, including but not limited to those for use of any products, loss of time, inconvenience, lost profit, labor charges, or other incidental or consequential damages with respect to persons, business, or property, whether as a result of breach of warranty, negligence or otherwise. Notwithstanding any other provision of this warranty, BUYER'S REMEDY AGAINST KEETON INDUSTRIES FOR GOODS SUPPLIED OR FOR NON-DELIVERED GOODS OR FAILURE TO FURNISH GOODS, WHETHER OR NOT BASED ON NEGLIGENCE, STRICT LIABILITY OR BREACH OF EXPRESS OR IMPLIED WARRANTY IS LIMITED SOLELY, AT KEETON INDUSTRIES' OPTION, TO REPLACEMENT OF OR CURE OF SUCH NONCONFORMING OR NON-DELIVERED GOODS OR RETURN OF THE PURCHASE PRICE FOR SUCH GOODS AND IN NO EVENT SHALL EXCEED THE PRICE OR CHARGE FOR SUCH GOODS. KEETON INDUSTRIES EXPRESSLY DISCLAIMS ANY WARRANTY OF MERCHANTABILITY OR FITNESS FOR A PARTICULAR USE OR PURPOSE WITH RESPECT TO THE GOODS SOLD. THERE ARE NO WARRANTIES WHICH EXTEND BEYOND THE DESCRIPTIONS SET FORTH IN THIS WARRANTY, notwithstanding any knowledge of Keeton Industries regarding the use or uses intended to be made of goods, proposed changes or additions to goods, or any assistance or suggestions that may have been made by Keeton Industries personnel.

Unauthorized extensions of warranties by the customer shall remain the customer's responsibility.

DURAPLATE DIFFUSERS ARE COVERED BY A SEPERATE LIFE TIME WARRANTY AGAINST MATERIAL DEFECTS OR CRAFTSMANSHIP.

This warranty can be modified only by authorized Keeton Industries personnel by signing a specific, written description of any modifications.

troubleshooting

	Low Pressure	High Pressure	Pump Overheat	Won't Start	Excess Noise	REASON & REMEDY
COMPRESSOR	•		•	•		Filter dirty. Clean or replace.
	•					Valves closed. Clean or replace.
	•					Worn cup. Repair or replace.
		•	•	•		Relief valve set too high. Inspect and adjust.
	•					Relief valve set too low. Inspect and adjust.
	•	•	•	•		Plugged pressure line. Inspect and repair.
			•	•		Low voltage, won't start. Check power source.
			•	•	•	Voltage wrong. Check power source.
	•				•	Worn cup/piston hitting cylinder. Replace.
			•		•	Cylinder misadjustment. Realign.
	•			•		Leaky hose or check valve. Replace.
	•		•	•	•	Dirt or liquid on top of piston. Inspect and clean.
	•		•	•	•	Motor not wired correctly. Check wiring diagram/line voltage.
				•		Timer set incorrectly. Inspect and adjust.
			•		Worn cooling blower. Clean or replace.	
•				•	Blown head gasket. Replace.	
DIFFUSERS	Uneven Air Flow	High Air Flow	Low Air Flow	Won't Start	"Burping" Bubbles	REASON & REMEDY
	•		•	•		Leak in System. Check all connections and tubing and repair.
	•	•	•	•		Manifold not set correctly. Inspect and adjust.
			•	•		Compressor Issue. See above.
					•	Damaged or torn Membrane. Replace.
•					Unbalanced Manifold. Inspect and adjust.	

© 2011 Keeton Industries, Inc. All rights reserved.

Other Ponds And Lakes Are Green With Envy® is a registered trademark and Solaer™, Duraplate™, Alpine™ Tubing and Quiet Line™ are trademarks of Keeton Industries, Inc. The Solaer Lake Bed Aeration Systems are protected by United States Patent No. 6,676,837.



...still having troubles? Contact us:

800.493.4831 or info@keetonaquatics.com

OTHER PONDS AND LAKES ARE GREEN WITH ENVY™

1520 Aquatic Drive, Wellington CO 80549 • KeetonAquatics.com • toll-free: 800.493.4831 • fax: 970.568.7795